

Professional Electrol®

Automatic Electric Projection Screen Model

SUGGESTED SPECIFICATIONS: _____ projection screen(s), _____(H) x _____(W), electrically operated 120 volt A.C. (60 Hz). Screen will have not more than 2.4 amp. motor. Shall have specially designed motor mounted inside the roller, to be three wire with ground, quick reversal type, oiled for life, with automatic thermal overload cutout, integral gears, capacitor and an electric brake to prevent coasting. To have preset but adjustable limit switches to automatically stop screen fabric in the "up" and "down" positions. Rigid metal roller, to be at least 3" in diameter (on screens 12' wide), 5¾" in diameter (on screens 14' to 18' wide) or 7" in

diameter (on screens where either height or width equal or exceed 20'). Roller to be mounted in one heavy duty bracket equipped with self-aligning bearing. Motor to be secured to the case with a steel motor mount bracket. Screen surface to be flame retardant and mildew resistant fiberglass with black masking borders standard. Case to be of wood, with double top for extra rigidity and strength. Case to be finished with a black primer coat, ready to accept final finish by others, heavy metal brackets shall be supplied for mounting screen to ceiling or wall. To be complete with 3 position control switch with cover plate. Screen to be listed by Underwriter's Laboratories.



HDTV (16:9) Format Dimensions (2" Standard Black Drop at Top)

Viewing Area (H x W)		Nominal Diagonal		Overall Length of Case		Approx. Hang. Wt.		Approx. Ship. Wt.	
In.	Cm	In.	Cm	In.	Cm	Lbs.	Kg	Lbs.	Kg
78" x 139"	198 x 353	159"	404	154"	391	207	93.9	483	219.1
92" x 164"	234 x 417	188"	478	178"	452	250	113.4	506	229.5
106" x 188"	269 x 478	216"	549	202"	513	296	134.2	615	279.0
119" x 212"	302 x 538	243"	617	226"	574	315	142.9	743	337.0
133" x 236"	338 x 599	271"	688	250"	635	413	187.3	830	376.5
146" x 260"	371 x 660	298"	757	274"	696	454	205.9	951	431.4
160" x 284"	406 x 721	326"	828	298"	757	495	224.5	1000	453.6

Wide (16:10) Format Dimensions (2" Standard Black Drop at Top)

Viewing Area (H x W)		Nominal Diagonal		Overall Length of Case		Approx. Hang. Wt.		Approx. Ship. Wt.	
In.	Cm	In.	Cm	In.	Cm	Lbs.	Kg	Lbs.	Kg
110" x 176"	279 x 447	208"	528	190"	483	270	122.5	512	232.2
117½" x 188"	298 x 478	222"	594	202"	513	286	129.7	605	274.4
132½" x 212"	337 x 538	250"	635	226"	574	320	145.1	748	339.3
147½" x 236"	375 x 599	278"	706	250"	635	419	190.1	836	379.2
177½" x 284"	451 x 721	335"	851	298"	757	502	227.7	1007	456.8

Video (NTSC 4:3) Format Dimensions (2" Standard Black Drop at Top)

Viewing Area (H x W)		Nominal Diagonal		Overall Length of Case		Approx. Hang. Wt.		Approx. Ship. Wt.	
In.	Cm	In.	Cm	In.	Cm	Lbs.	Kg	Lbs.	Kg
120" x 160"	305 x 406	200"	508	174"	442	252	114.3	540	244.9
123" x 164"	312 x 417	210"	533	178"	452	258	117.0	500	226.8
141" x 188"	358 x 478	240"	610	202"	513	292	132.4	628	284.9
159" x 212"	404 x 538	265"	673	226"	574	329	149.2	731	331.6
177" x 236"	450 x 599	295"	749	250"	635	429	194.6	850	385.6
195" x 260"	495 x 660	325"	826	274"	696	474	215.0	927	420.5
213" x 284"	541 x 721	355"	902	298"	757	518	234.9	1019	462.2

Square Format Dimensions

Size (H x W)		Overall Length of Case		Approx. Hang. Wt.		Approx. Ship. Wt.	
In.	Cm	In.	Cm	Lbs.	Kg	Lbs.	Kg
12' x 12'	366 x 366	154"	391	222	100.7	472	214.1
14' x 14'	427 x 427	178"	452	270	122.4	568	257.6
16' x 16'	488 x 488	202"	513	307	139.2	650	294.8
18' x 18'	549 x 549	226"	574	347	157.4	745	337.9
20' x 20'	610 x 610	250"	635	452	205.0	915	415.0
22' x 22'	671 x 671	274"	696	501	227.2	943	427.7

PRODUCT NOTES:

- **Matte White:** Horizontal seam required when both dimensions exceed 16'.
- Detailed dimensional drawings, wiring diagrams and installation instructions available upon request.
- **DO NOT SEAL IN — ALLOW ACCESS —** Recessed installation requires access to screen roller.
- **FOR EXPOSED INSTALLATION —** If the screen is to be mounted in an exposed position, it may be covered with finished plywood, veneer, paneling, plastic wall covering or a valance.
- Overall case length dimensions +/- 1/4" (6mm).
- Specifications subject to change without notice.
- Custom formats and sizes available upon request.

WHEN ORDERING, MARK APPROPRIATE SELECTIONS

1. Select size from charts above.
2. Select viewing surface (All Da-Lite surfaces are GREENGUARD GOLD Certified.):
Matte White
3. Options:
Extra Drop available to lower picture area more than normal. Specify total drop at top _____ (black or white) or at bottom _____ (black or white). 22' maximum total surface height including picture area, except for 24' wide, where maximum drop is 18'.
No Borders (Black masking borders standard)
220 Volt (50 Hz) Motor
White box (black standard)
4. Optional Accessories:
External Low Voltage Control (LVC)
Screen Controller (TCP/IP, RS232, Dry Contact, and VPI/Trigger). (NOTE: Requires Integrated or External LVC)
Radio Frequency (BLE) Remote
Infrared Remote
PoE Injector
Key Locking Cover Plate for 120V or LVC Switch
Key Operated Switch for 120V only (NOTE: Cannot be used with LVC)

PRODUCT VIEWS

SUGGESTED METHODS OF INSTALLATION

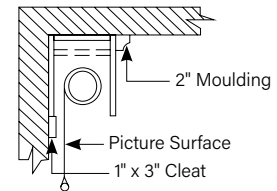
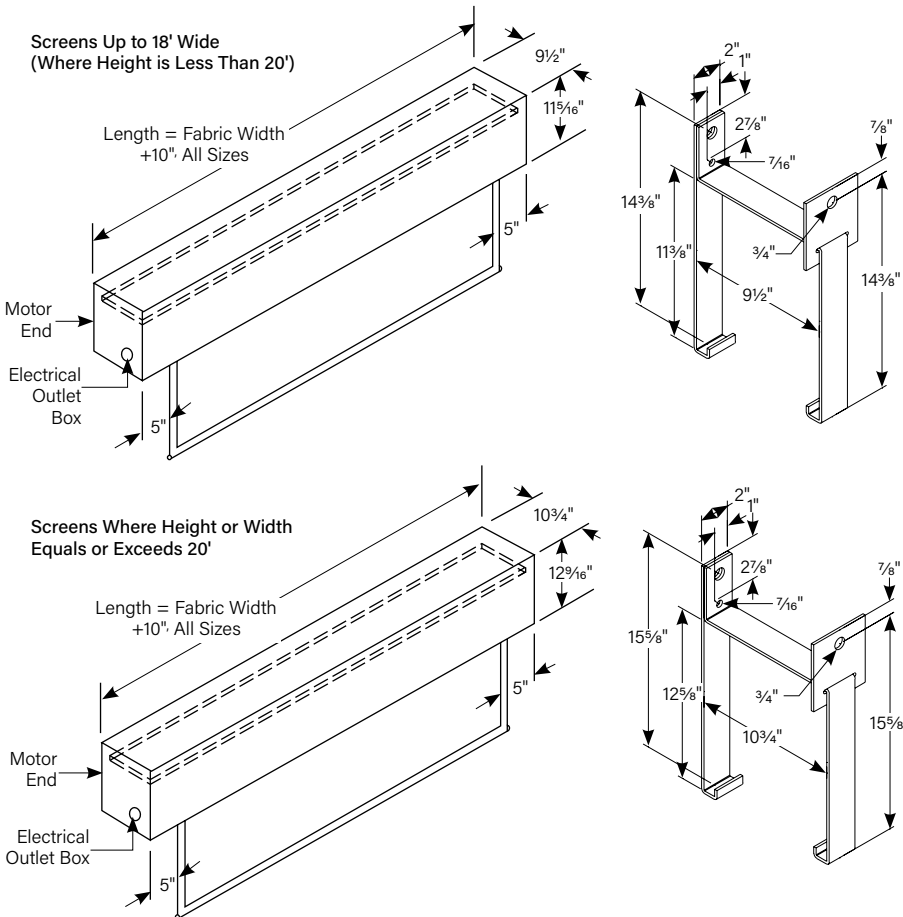

Ceiling Mount Without Hangers
Screen case is placed flush with the wall and ceiling and held in position by moulding securely attached to the wall

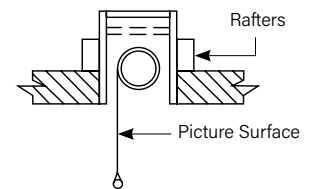

Recessed Above Ceiling
Other methods of installation will suggest themselves in new buildings where it would be an easy matter to provide a recess for the screen to conceal it when not in use. **Do not seal in — allow access.**

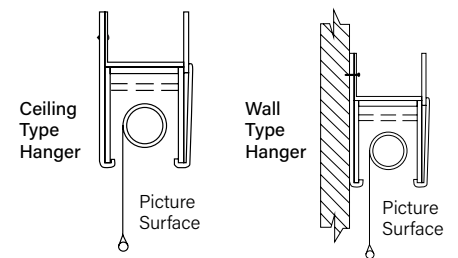

Wall Or Ceiling Mount With Hangers
Wall type hangers and ceiling type hangers are standard equipment. One set is supplied with each screen. Useful for recessed installations

Project Name: _____
Architect: _____
Contractor: _____ Phone: _____
Reseller: _____ Phone: _____

LEGRAND | AV COMMERCIAL BRANDS
C2G | Chief | Da-Lite | Luxul | Middle Atlantic | Vaddio | Wiremold

FOR YOUR IMAGE | legrandav.com

USA 866.977.3901 av.da-lite.support@legrand.com CANADA 877.345.4329 av.da-lite.support@legrand.com

EMEA +31 495 580 840 av.emea.sales@legrand.com APAC +852 2145 4099 av.asia.sales@legrand.com