

Tensioned Cosmopolitan®

Previously Named: Tensioned Cosmopolitan Electrol®

SUGGESTED SPECIFICATIONS: _____ projection screen(s), _____(H) x _____(W), electrically operated 120 volt (60 Hz) not more than 2.4 amp. To have seamless surfaces with black masking borders standard on flame retardant and mildew resistant fabric mounted on rigid metal roller. Each side of the fabric to have tab guide cable system to maintain even lateral tension and hold surface flat. Custom slat bar with added weight maintains vertical tension on the screen surface. The ends of the slat to be protected by heavy duty plastic caps enclosing a preset adjustable mechanism for screen tensioning. Shall have specially designed motor mounted inside the roller, to be three wire with ground, quick reversal

type, oiled for life, with automatic thermal overload cutout, integral gears, capacitor and an electric brake to prevent coasting. To have preset but adjustable limit switches to automatically stop picture surface in the "up" and "down" position. Case to be powder coated white 21-gauge steel, hexagon in shape with flat back to prevent scraping fabric. Case end caps to be heavy duty, allowing no exposed roller pins. Caps shall form sturdy brackets for wall or ceiling installation. To be complete with three position control switch with cover plate. Screen to be listed by Underwriters' Laboratories.



HDTV (16:9) Format Dimensions

Viewing Area (H x W)		Nominal Diagonal		Overall Case Length		Between Hanger Eyes		Approx. Ship. Wt.	
In.	Cm	In.	Cm	In.	Cm	In.	Cm	Lbs.	Kg
45" x 80"	114 x 203	92"	234	98½"	250	97"	246	84	38.1
52" x 92"	132 x 234	106"	269	111"	282	109½"	278	91	41.3
54" x 96"	137 x 244	110"	279	115½"	293	114"	290	93	42.2
58" x 104"	147 x 264	119"	302	124"	315	122½"	311	100	45.4
65" x 116"	165 x 295	133"	338	137"	348	135½"	344	110	49.9
78" x 139"	198 x 353	159"	404	162"	411	160½"	408	130	59.0

Wide (16:10) Format Dimensions

Viewing Area (H x W)		Nominal Diagonal		Overall Case Length		Between Hanger Eyes		Approx. Ship. Wt.	
In.	Cm	In.	Cm	In.	Cm	In.	Cm	Lbs.	Kg
50" x 80"	127 x 203	94"	239	99"	251	97½"	248	83	37.6
57½" x 92"	146 x 234	109"	277	112"	284	110½"	281	89	40.4
60" x 96"	152 x 244	113"	287	116½"	296	115"	292	95	43.1
65" x 104"	165 x 264	123"	312	125"	318	123½"	314	102	46.3
69" x 110"	175 x 279	130"	330	131½"	334	130"	330	105	47.6
72½" x 116"	184 x 295	137"	348	138"	351	136½"	347	116	52.6
87" x 139"	221 x 353	164"	417	159"	404	157½"	400	130	59.0

Video (NTSC 4:3) Format Dimensions

Viewing Area (H x W)		Nominal Diagonal		Overall Case Length		Between Hanger Eyes		Approx. Ship. Wt.	
In.	Cm	In.	Cm	In.	Cm	In.	Cm	Lbs.	Kg
43" x 57"	109 x 145	72"	183	75"	191	73½"	187	63	28.6
50" x 67"	127 x 170	84"	213	86"	218	84½"	215	72	32.7
60" x 80"	152 x 203	100"	254	100"	254	98½"	250	83	37.6
69" x 92"	175 x 234	120"	305	114"	290	112½"	286	96	43.5
87" x 116"	221 x 295	150"	381	141"	358	139½"	354	118	53.5

PRODUCT NOTES

- All viewing surfaces will be seamless.
- All viewing surfaces are standard with black backing except Da-Tex® and HD Progressive ReView 0.9.
- All screens standard with 12" black drop at the top.
- Extra drop may alter dimensions. Contact Da-Lite for details.
- Overall case length dimensions +/- ¼" (6mm).
- Specifications subject to change without notice.
- Custom formats and sizes available upon request.

WHEN ORDERING, MARK APPROPRIATE SELECTIONS

1. Select size from charts on the other side.
2. Select viewing surface.
(All Da-Lite surfaces are GREENGUARD GOLD Certified):
Da-Mat®
HD Progressive ReView 0.9 (Rear)
Da-Tex® (Rear)

3. Options:

- Integrated Low Voltage Control (LVC)
- Silent Motor (available on screens up to 10' wide)
- Silent Motor with Integrated LVC (available on screens up to 10' wide)

- 220 Volt (50 Hz) Motor
- Black case (white standard)

4. Optional Accessories:

- External Low Voltage Control (LVC)
- Screen Controller (TCP/IP, RS232, Dry Contact, and VPI/Trigger). (NOTE: Requires Integrated or External LVC)
 - Radio Frequency (BLE) Remote
 - Infrared Remote
 - PoE Injector
- Key Locking Cover Plate for 120V or LVC Switch

- Key Operated Switch for 120V only (NOTE: Cannot be used with LVC)
- Floating Mounting Bracket (black or white). Recommended for drywall installations.
- No. 6 Wall Bracket - 6" extension, non-adjustable (140# maximum per pair) (black or white)
- Ceiling Trim Kit - built-in LVC recommended

PRODUCT VIEW

SUGGESTED METHODS OF INSTALLATION

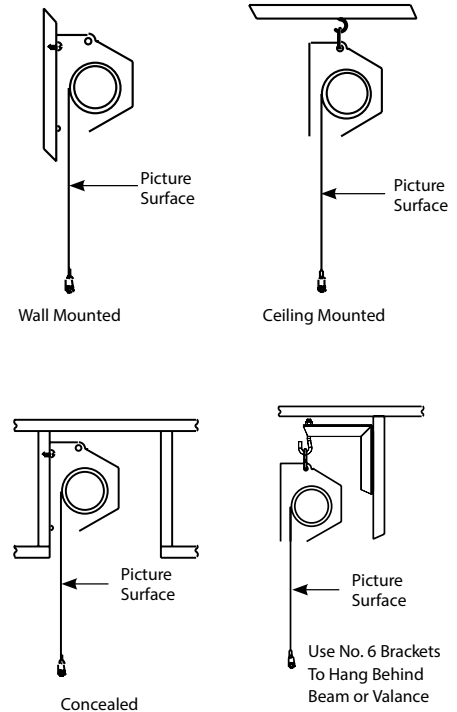
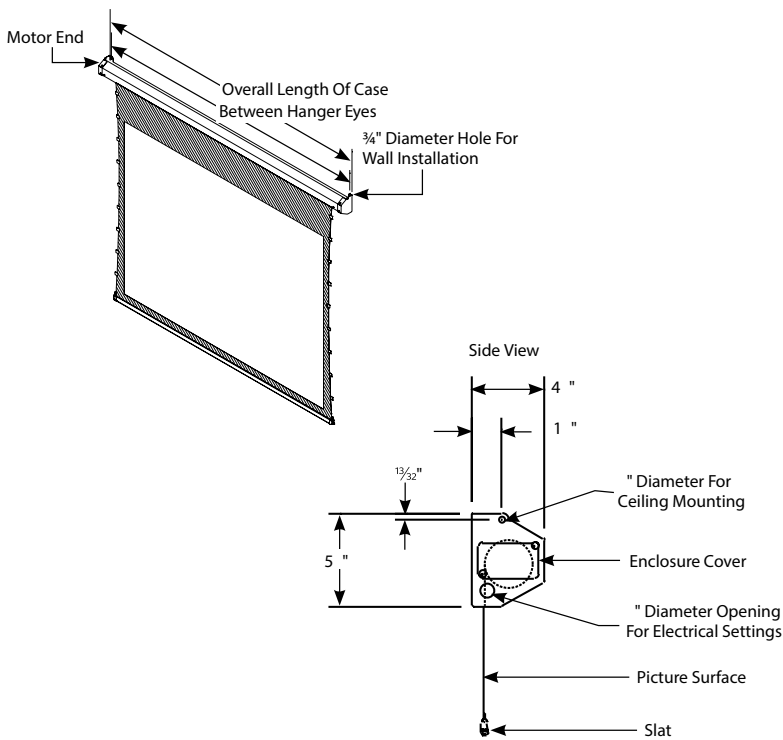

Project Name: _____

Architect: _____

Contractor: _____ Phone: _____

Reseller: _____ Phone: _____

Tensioned Cosmopolitan® (Over 12' W)

Previously Named: Tensioned Cosmopolitan Electrol®

SUGGESTED SPECIFICATIONS: _____ projection screen(s), _____(H) x _____(W), electrically operated 120 volt (60Hz) not more than 2.4 amp. Shall have specially designed motor mounted inside the roller, to be three wire with ground quick reversal type, oiled for life, with automatic thermal overload cut-out, integral gears, capacitor and an electric brake to prevent coasting. To have pre-set but adjustable limit switches to automatically stop picture surface in the "up" and "down" positions. The roller to be of aluminum. Screen fabric to be mildew resistant vinyl with black masking borders standard. Each side of fabric to have a tab guide cable system to maintain even lateral tension and hold surface flat.

Bottom of fabric to be inserted into a custom aluminum slat bar with added weight to provide vertical tension on the screen surface. The ends of the slat to be protected by heavy duty plastic caps enclosing a preset adjustable mechanism for screen tensioning. Case to be a two-piece design made of extruded aluminum with a white, lightly textured powder coat finish. Screen to include a three-position control switch and cover plate. Screen to be listed by Underwriters' Laboratories.



HDTV (16:9) Format Dimensions

Viewing Area (H x W)		Nominal Diagonal		Overall Case Length		Approx. Hanging Wt.		Approx. Ship. Wt.	
In.	Cm	In.	Cm	In.	Cm	Lbs.	Kg	Lbs.	Kg
92" x 164"	234 x 417	188"	478	186"	472	182	82.6	400	181.4
108" x 192"	274 x 488	220"	559	215½"	547	211	95.7	472	214.1

Wide (16:10) Format Dimensions

Viewing Area (H x W)		Nominal Diagonal		Overall Case Length		Approx. Hanging Wt.		Approx. Ship. Wt.	
In.	Cm	In.	Cm	In.	Cm	Lbs.	Kg	Lbs.	Kg
100" x 160"	254 x 406	189"	480	182½"	464	181	82.1	390	176.0
110" x 176"	279 x 447	208"	528	199¾"	507	198	89.8	441	200.0
120" x 192"	305 x 488	226"	574	217"	551	216	98.0	478	216.8

Video (NTSC 4:3) Format Dimensions

Viewing Area (H x W)		Nominal Diagonal		Overall Case Length		Approx. Hanging Wt.		Approx. Ship. Wt.	
In.	Cm	In.	Cm	In.	Cm	Lbs.	Kg	Lbs.	Kg
108" x 144"	274 x 366	180"	457	167½"	425	173	78.5	369	167.4
120" x 160"	305 x 406	200"	508	185"	470	187	84.8	398	180.5
126" x 168"	320 x 427	210"	533	194"	493	196	88.9	432	196.0
132" x 176"	335 x 447	220"	559	203"	516	205	93.0	452	205.0
144" x 192"	366 x 488	240"	610	220½"	560	224	101.6	489	221.8

PRODUCT NOTES

- All viewing surfaces will be seamless.
- All viewing surfaces are standard with black backing except for Da-Tex® and HD Progressive ReView 0.9.
- All screens standard with 12" black drop at the top.
- Extra drop may alter case dimensions. Contact Da-Lite for details.
- Overall case length dimensions +/- ¼" (6mm).
- Detail dimensional drawings, wiring diagrams and installation instructions available upon request.
- Specifications subject to change without notice.
- Custom formats and sizes available upon request.
- All HD Progressive, Da-Mat, and Da-Tex surfaces are fire retardant.

WHEN ORDERING, MARK APPROPRIATE SELECTIONS

1. Select size from charts on the other side.
2. Select viewing surface.
(All Da-Lite surfaces are GREENGUARD GOLD Certified):
 - Parallax Stratos 1.0
 - HD Progressive 1.0
 - HD Progressive 1.1 Contrast
 - HD Progressive 1.3
 - Da-Mat®
 - Da-Tex® (Rear)
 - HD Progressive ReView 0.9 (Rear)

3. Options:

Single Motor Low Voltage Control System (LVC) – built-in
 220 Volt (50 Hz) Motor

Black case (white standard)

4. Optional Accessories:

Single Motor Low Voltage Control System (LVC)
 – external

Key Operated Switch for 120V only
 (NOTE: Cannot be used with LVC)

Key Locking Cover Plate for 120V
 or LVC Switch

PRODUCT VIEW

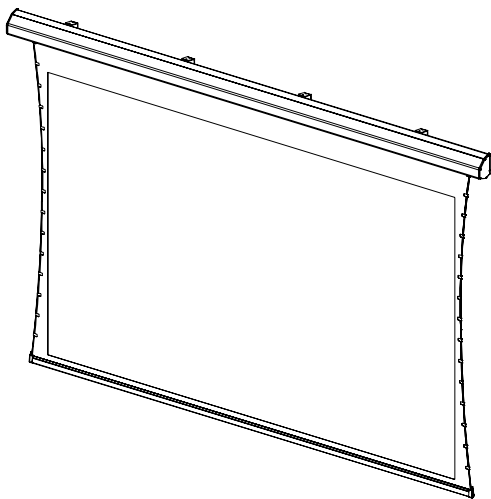

SUGGESTED METHODS OF INSTALLATION

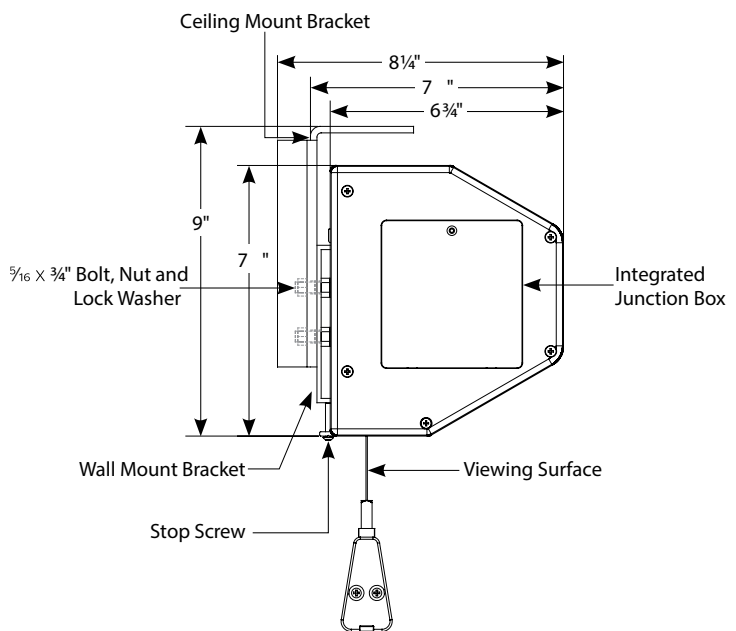

Project Name: _____
Architect: _____
Contractor: _____ Phone: _____
Reseller: _____ Phone: _____

LEGRAND | AV COMMERCIAL BRANDS

C2G | Chief | Da-Lite | Luxul | Middle Atlantic | Vaddio | Wiremold

FOR YOUR IMAGE | legrandav.com

USA 866.977.3901 av.da-lite.support@legrand.com CANADA 877.345.4329 av.da-lite.support@legrand.com

EMEA +31 495 580 840 av.emea.sales@legrand.com APAC +852 2145 4099 av.asia.sales@legrand.com